



LFP 5-10kWh / LV

51.2V 100/200Ah

LiFePO4 BATTERY



High inverter compatibility



Natural cooling system



>15 Years life span



Reliable LFP cells



Scalable up to 160kWh 16 (Parallel)



Cells cycle times 6000 cycles



CANbus standard connection



IP65 Rating Triple hardware protection



Smart BMS system to optimize the performance



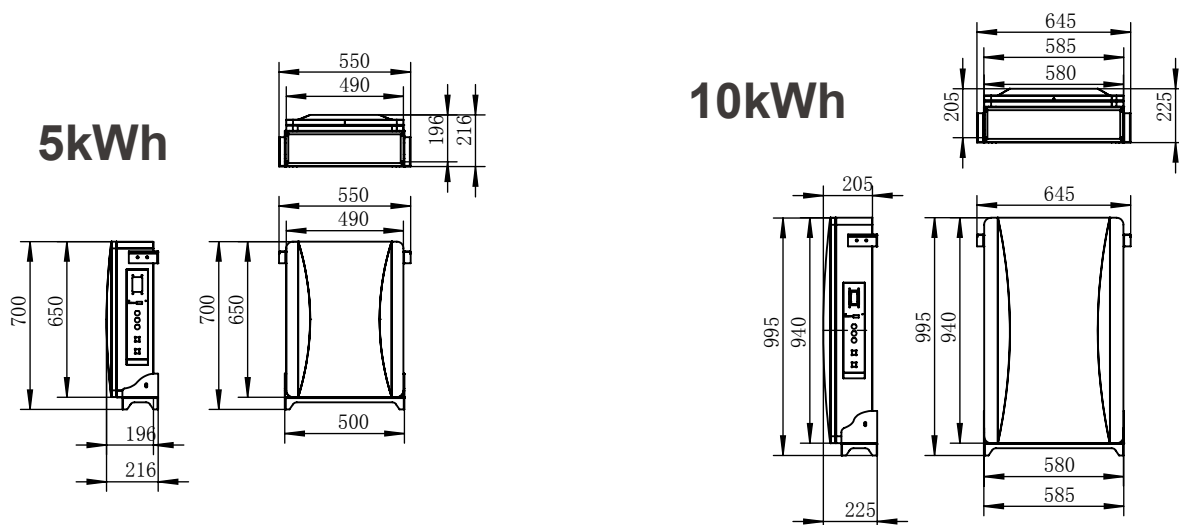

Electrical Characteristics

Module Type	LFP 5kWh/LV	LFP 10kWh/LV
Total Energy*	5kWh	10kWh
Usable Energy(DC)*	4.6kWh	9.2kWh
Nominal Dis-/Charge Power	3kW	4.6kW
Peak Power _(Only Discharge)	7kWh for 3 seconds	10kWh for 3 seconds
Constant Current _(Only Discharge)	100A	100A
Voltage	48~56Vd.c	48~56Vd.c
Nominal Voltage	51.2Vd.c	51.2Vd.c
Nominal Current	60A	100A
Max. Charge Voltage	59.2V±0.5V d.c	59.2V±0.5V d.c
Weight	65kg	125kg
Dimension(mm)	490(550)*650(700)*196(216)mm	585(645)*940(995)*205(225)mm
Safety	CE UN38.3	CE UN38.3
Max.recommended DOD	90%	
Operating Condition	Indoor or outdoor	
Operating Charge Temperature	From 0~45 °C	
Discharge Temperature	From -10~50 °C	
Humidity	4~100% (No condensed water)	
Pollution Degree	3	
Over Voltage Category	II	
Cooling Type	Natural cooling	
Case Material	Metal+Plastic	
IP rating	IP 65	
Protective Class	I	
Max. Number of Parallel or Series	16	
Warranty	10 years	
Life Span	>15 years	
Communication	CAN	
Protection Mode	Triple hardware protection	
Battery Protection	Over-current/Over-voltage/Short circuit/ Under-voltage	
Hazardous Material Classification	9	

Compatible Inverters



www.sunketess.com

sales@sunket.cn